

Tachogenerators

Blind hollow shaft $\varnothing 10$ to $\varnothing 16$ mm

Nominal voltage 10 VDC to 60 VDC

KTD 3-... A 4 Y 2

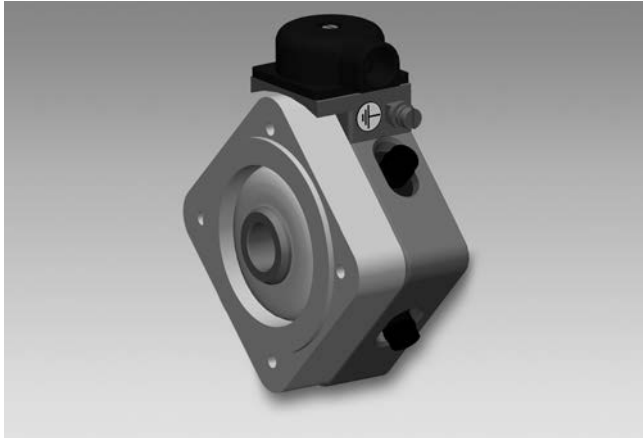

KTD 3-... A 4 Y 2 with blind hollow shaft

Features

- High response speed
- Blind hollow shaft $\varnothing 10 \dots 16$ mm
- Centering alignment $\varnothing 70$ mm, mounting screw hole circle $\varnothing 77$ mm
- Rotor fastening by ring clamping element
- Wide rotation speed range
- Recognition of sense of rotation
- Low harmonic content
- No auxiliary energy source required

Technical data - electrical ratings

Polarity	Depending on rotational direction
Number of pole pairs	2 = 4 poles
Number of grooves, segments	29
Groove frequency	$f_N = 29/30 \times n$
Reversal tolerance	≤ 0.1 %
Linearity tolerance	≤ 0.15 %
Residual ripple	$\leq 0,4$ %
Adjustment tolerance (Nominal voltage)	$\leq \pm 10$ %
Lower limit of control range	0 rpm
Temperature coefficient	± 0.1 %/10 K (-10...+100 °C)
Isolation class	B
Carbon brush lifetime approx.	20000 Operating hours
Carbon brush	4 pieces 3 x 4 x 12
Nominal voltage	10...60 V
Maintenance	After approx. 10 000 hours in service
Interference immunity	DIN EN 61000-6-2
Emitted interference	DIN EN 61000-6-3

Technical data - mechanical design

Shaft type	$\varnothing 10 \dots 16$ mm (blind hollow shaft)
Protection DIN EN 60529	IP 54
Rotor moment of inertia	600 gcm ² (KTD 3-1 - KTD 3-3) 910 gcm ² (KTD 3-4 - KTD 3-6)
Material	Housing: aluminium, bare / steel zinc-coated
Operating temperature	-20...+100 °C
Connection	Terminal box, 2-pin

Tachogenerators

Blind hollow shaft $\varnothing 10$ to $\varnothing 16$ mm
Nominal voltage 10 VDC to 60 VDC

KTD 3-... A 4 Y 2

Part number

KTD 3- A 4 Y 2

	Nominal voltage
1	10 V
2	20 V
3	30 V
4	40 V
6	60 V

When ordering please specify hollow shaft diameter.

Terminal assignment

Marking	Polarity
A1	positive
A2	negative

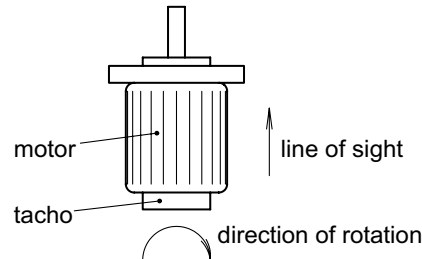

Data according to type

Type	Rated voltage U_N [mV/min ⁻¹]	Rated current I_N [mA]	max. current I [mA]	max. revolution n [min ⁻¹]	Armature resistance R_A (20°C) [Ω]	Weight rotor	Weight housing
(Electrical data according to 1000 rpm)							
KTD 3-1 A 4 Y 2	10	10	100	6000	45	250 g	440 g
KTD 3-2 A 4 Y 2	20	10	80	6000	170	250 g	440 g
KTD 3-3 A 4 Y 2	30	10	80	6000	170	250 g	440 g
KTD 3-4 A 4 Y 2	40	10	80	4000	220	360 g	570 g
KTD 3-6 A 4 Y 2	60	30	80	3000	220	360 g	570 g

Dimensions

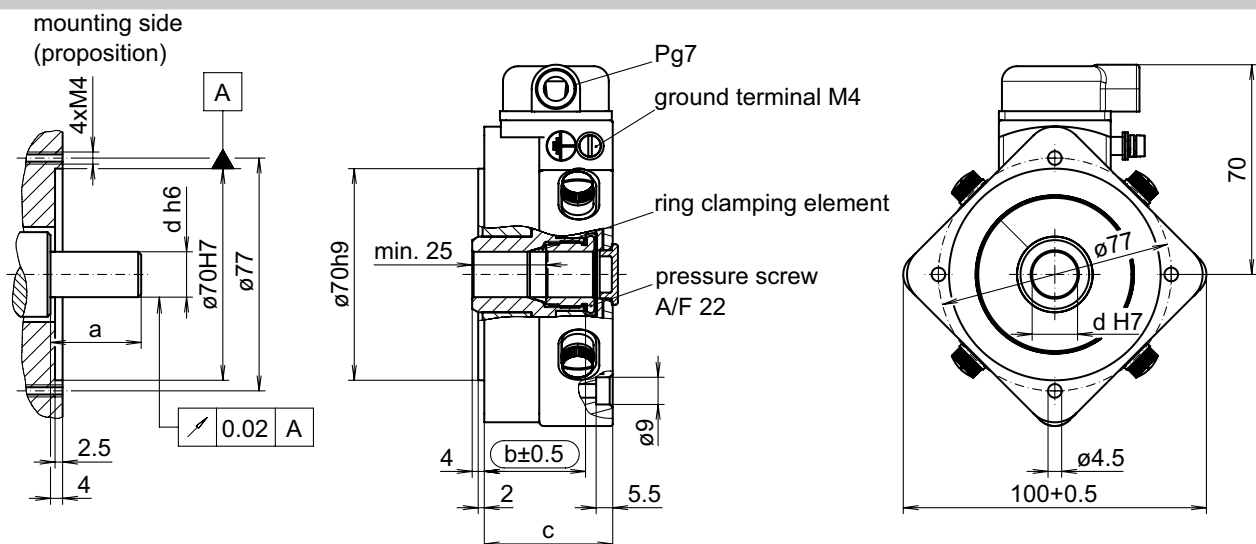

Type	VDC	a	b	c
KTD 3-1 A 4 Y 2	10	30	33.5	42.5
KTD 3-2 A 4 Y 2	20	30	33.5	42.5
KTD 3-3 A 4 Y 2	30	30	33.5	42.5
KTD 3-4 A 4 Y 2	40	40	43.5	52.5
KTD 3-6 A 4 Y 2	60	40	43.5	52.5

optional	d
	10
	12
	14
	15
16	

014- 5 Y 2