

参考図

p11216 2017/01/26 09:47:17

電気的零位置記号(参考位置)
ELECTRICAL ZERO MARK(REF)

詳細図
DETAIL

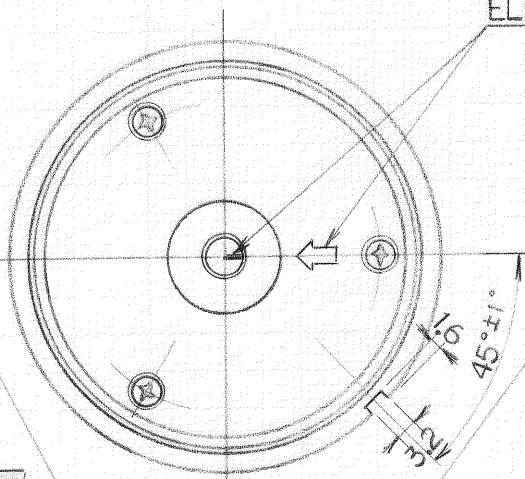
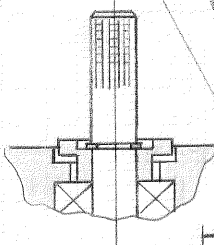

インボリュートスプライン SPLINE DATA

ピッチ PITCH	96
歯数 NUMBER OF TEETH	22
圧力角 PRESSURE ANGLE	20°
外径 OUTSIDE DIAMETER	$\phi 61.0_{-0.01}^0$
ピッチ径 PITCH DIAMETER	$\phi 58.2_{-0.05}^0$
有効長 FULL SPLINE DEPTH	10
ネジ THREAD	1/4-28NF-3
外径 MAJOR DIAMETER	$\phi 6.1_{-0.05}^0$
有効長 FULL THREAD DEPTH	7

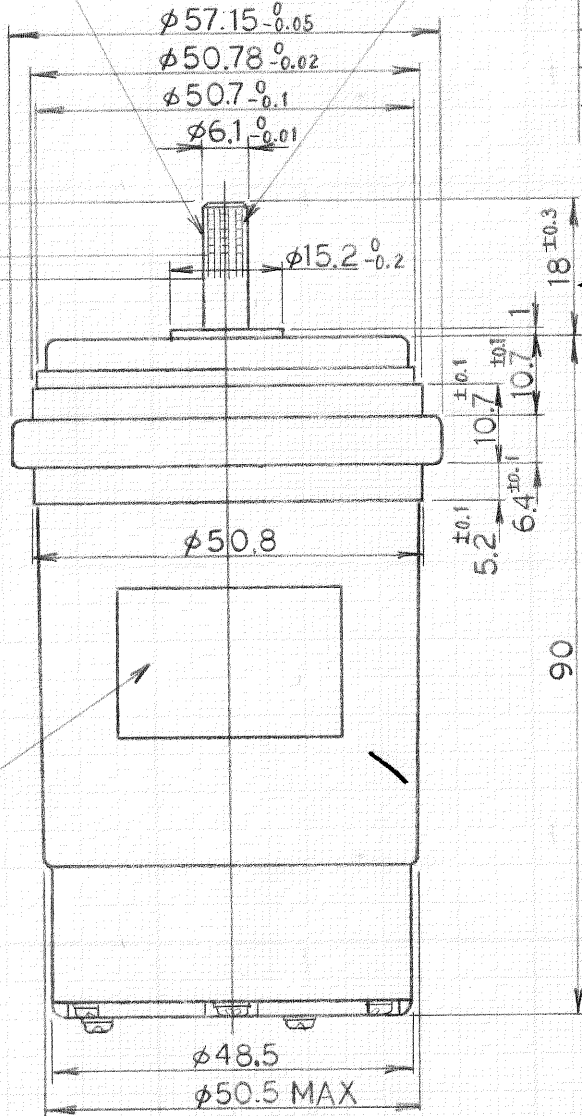

結線図
WIRING DIAGRAM

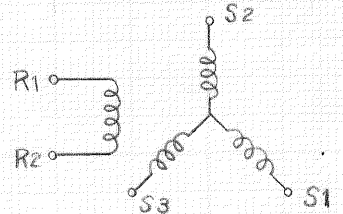

矢視
VIEW A

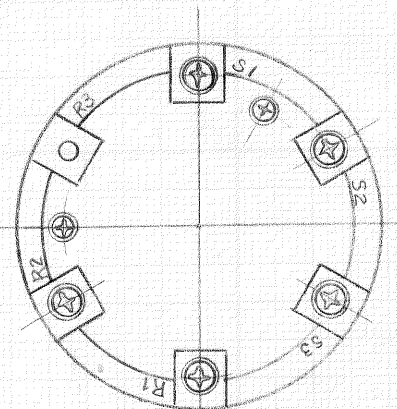

銘板
NAME PLATE

UNLESS OTHERWISE SPECIFIED,
TOLERANCES ARE $\pm 1.0\%$

DIMENSION in mm

REV. 2	DATE 3. Apr. '76	SCALE 1/1	TYPENO.	TITLE シンクロ電機 SYNCHRO
DS'D K. Marabe	DATE 6. Apr. '81	SCALE	TYPENO.	TITLE シンクロ電機 SYNCHRO
CH'D	DATE	SCALE	TYPENO.	TITLE シンクロ電機 SYNCHRO
APP'D S. Ishiyama	DATE	SCALE	TYPENO.	TITLE シンクロ電機 SYNCHRO
TAMAGAWA SEIKI CO., LTD TOKYO, JAPAN				DWG. NO. F 28465
SHEET				OF

004660003F40 TS466N60N61

004660003F40

参考図

SYNCHRO 仕様書 specification

P1215 2017/01/26 09:50:20

形式 type	TS466N60E17	TX
------------	-------------	----

適用書類 document	外形図 outline	F 28465 (004660003F40)
	銘板 nameplate	N #68 ^A 4901
	準拠規格 standard	

項目 requirement	仕様 value	備考 note
電源 power source	115 volts 60 Hz	
試験電源 test source	115 volts 60 Hz	
無負荷励磁電流 primary current	230 mA max	
一次電力 primary power	6 watts max	
二次電圧 (変圧比) secondary voltage or transformation ratio	0.783 ± 2%	
電気誤差 electrical error	ロータ rotor	minutes max
	ステータ stator	± 8 minutes max
相度誤差 receiver error	degrees max	
残留電圧 null voltage	mV max	
安定度 synchronizing time	seconds max	
トルク率 torque gradient	8.5 g-cm/deg min	
温度上昇 temperature rise	60 °C max	抵抗法 resistance method
絶縁耐圧 dielectric strength	AC 1000 volts 1 minute	50・60Hz 漏れ電流10mA leakage curr.
絶縁抵抗 insulation resistance	10 MΩ min	DC 500 volts
重量 weight	1K grams max	
摩擦トルク friction torque	14 ²⁵ g-cm max	at 20 °C
表面処理 finish	アキヒナイトクレ-塗料 Gray lacquer coating	

0046600026540

REVISION	GE-PF	DIMENSION mm	
ST-PT 17.12.10	23 Oct. 78		
DWN	DATE	SCALE	TYPE NO.
DSI'D K. H. ...	4.9.1976	/	TS466N60E17
CH'D T. Watanabe	3RD ANGLE PROJECTION		TITLE シンクロ電機仕様書
APP'D O. Tsukota	TAMAGAWA SEIKI CO., LTD		synchro specification
APP'D	TOKYO, JAPAN		BWG. NO
			SHEET OF