

Recommended mating shafts

HOLLOW SHAFT ENCODERS

SERIES 500, 600, 700, 800, 900

Leine & Linde AB
T +46-(0)152-265 00
F +46-(0)152-265 05
info@leinelinde.com
www.leinelinde.com

Publication date: 2013-09-25

LEINE  LINDE

Contents

1 FIXING PRINCIPLES FOR DIFFERENT TYPES OF HOLLOW SHAFTS	4
1.1 BLIND HOLLOW SHAFT WITH CLAMPING RING AND STATOR COUPLING	4
1.2 THROUGH-GOING HOLLOW SHAFT WITH CLAMPING RING	4
1.3 BLIND HOLLOW SHAFT WITH AXIAL FIXING SCREW	4
2 MATING SHAFTS	5
2.1 500 SERIES	5
2.1.1 Blind hollow shaft with clamping ring (with/without stator coupling)	5
2.1.2 Through-going hollow shaft with clamping ring (with/without stator coupling)	5
2.1.3 Blind hollow shaft with axial fixing screw	5
2.2 600 SERIES	6
2.2.1 Blind hollow shaft with clamping ring and stator coupling	6
2.2.2 Through-going hollow shaft with clamping ring and stator coupling	6
2.3 700 SERIES	7
2.3.1 Through-going hollow shaft with clamping ring	7
2.4 800 SERIES	8
2.4.1 Blind hollow shaft with axial fixing screw	8
2.4.2 Blind hollow shaft with axial fixing screw and keyway	8
2.4.3 Through-going hollow shaft with clamping ring	8
2.4.4 Taper hollow shaft with axial fixing screw	8
2.5 900 SERIES	9
2.5.1 Taper hollow shaft with axial fixing screw	9
2.5.2 Blind hollow shaft with axial fixing screw	9
2.5.3 Blind hollow shaft with axial fixing screw and keyway	9
3 SHAFT RUNOUT	10
4 TORQUE ARMS	10
4.1 ACCESSORY TORQUE ARMS	10
4.1.1 Mounting with M6 torque arm	10
4.1.2 Alt. mounting with M5 torque arm	10

Please, note: More extensive mounting instructions are delivered with each encoder.

Leine&Linde AB claims copyright on this documentation. It is not allowed to modify, extend or to hand over to a third party and/or copy this documentation without written approval from Leine&Linde AB.

Specifications and content in this document are subject to change without prior notice due to our continuous strives to improve functionality and performance of our products.

1 Fixing principles for different types of hollow shafts

1.1 Blind hollow shaft with clamping ring and stator coupling

If space is limited radially, a good solution is to choose an encoder with a blind hollow shaft. This feature makes an axial output possible, which avoids adding anything to the radius. To prevent the encoder rotating with the shaft, it is fitted with a flexible stator coupling, which has also been designed to add as little as possible to the radius.

- Key characteristic: Minimal radial space
- Fixing: Clamping ring
- Available in the 600 and 500 serie

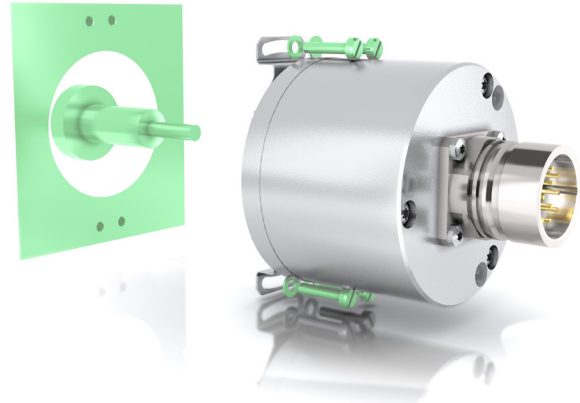

1.2 Through-going hollow shaft with clamping ring

This assembly is the most space-efficient axially. The encoder's hollow shaft is mounted directly on to the mating shaft, meaning there are no protruding shafts or intermediate couplings taking up valuable space. A clamping ring is used to fix the encoder to the mating shaft.

- Key characteristic: Short build length
- Fixing: Clamping ring
- Available in the 800, 700, 600 and 500 series

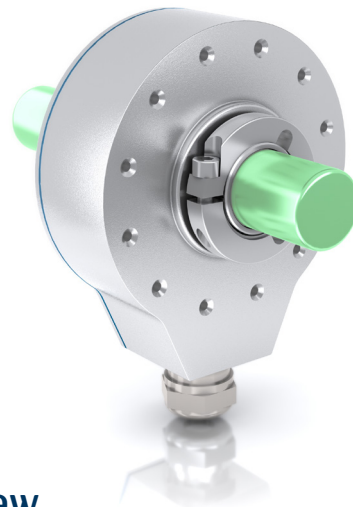

1.3 Blind hollow shaft with axial fixing screw

A common fixing solution is to secure the encoder's hollow shaft to the mating shaft using an axial screw. With a prepared mating shaft, assembly can be performed quickly and easily, during both manufacture of the machine and servicing. This solution also facilitates the process of centering the encoder to the mating shaft.

- Key characteristic: Easily accessible assembly
- Fixing: Axial screw
- Available in the 800 and 500 series



 = Part from customer

2 Mating shafts

2.1 500 series

2.1.1 Blind hollow shaft with clamping ring (with/without stator coupling)

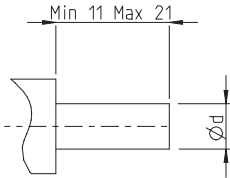

Dimensions [mm]

Ød	Tolerance
8	js6
10	js6
12	js6
14	js6
15	js6

2.1.2 Through-going hollow shaft with clamping ring (with/without stator coupling)

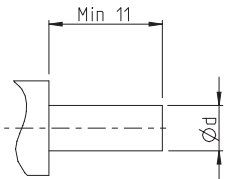

Dimensions [mm]

Ød	Tolerance
8	js6
10	js6
12	js6
14	js6
15	js6

2.1.3 Blind hollow shaft with axial fixing screw

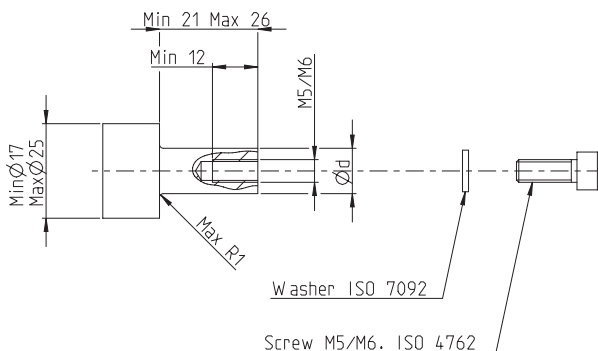

Dimensions [mm]

Ød	Tolerance
12	js6

When a 26 mm mating shaft is used the recommended screw length is 20 mm. If the shaft is made shorter the length of the screw must be prolonged accordingly so that minimum 9 mm thread is in use.

2.2 600 series

2.2.1 Blind hollow shaft with clamping ring and stator coupling

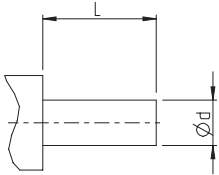

Dimensions RHA series [mm]

Ød	Tolerance	L = Min/Max
12	g7	11 / 21 mm

Dimensions IHA series [mm]

Ød	Tolerance	L = Min/Max
12	g7	11 / 31 mm

2.2.2 Through-going hollow shaft with clamping ring and stator coupling

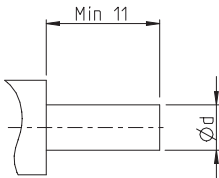

Dimensions [mm]

Ød	Tolerance
12	g7

2.3 700 series

2.3.1 Through-going hollow shaft with clamping ring

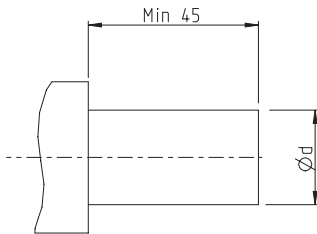

Dimensions

Ød	Tolerance
12 mm	g6
14 mm	g6
16 mm	g6
20 mm	g6
25 mm	g6
5/8 inch	g6
3/4 inch	g6
1 inch	g6

2.4 800 series

2.4.1 Blind hollow shaft with axial fixing screw

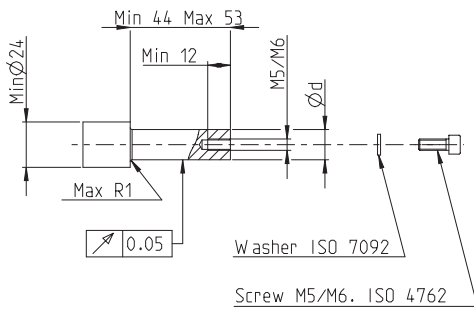

Dimensions [mm]

Ød	Tolerance
12	js6
16	js6

When a 53 mm mating shaft is used the recommended screw length is 16 mm. If the shaft is made shorter the length of the screw must be prolonged accordingly so that minimum 9 mm thread is in use.

2.4.2 Blind hollow shaft with axial fixing screw and keyway

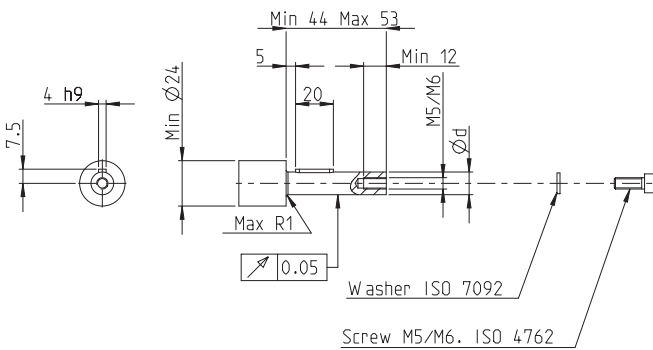

Dimensions [mm]

Ød	Tolerance
12	js6

When a 53 mm mating shaft is used the recommended screw length is 16 mm. If the shaft is made shorter the length of the screw must be prolonged accordingly so that minimum 9 mm thread is in use.

2.4.3 Through-going hollow shaft with clamping ring

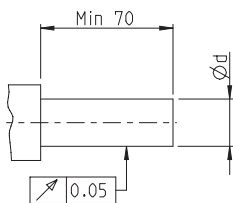

Dimensions

Ød	Tolerance
1 inch	g6
25 mm	g6

2.4.4 Taper hollow shaft with axial fixing screw

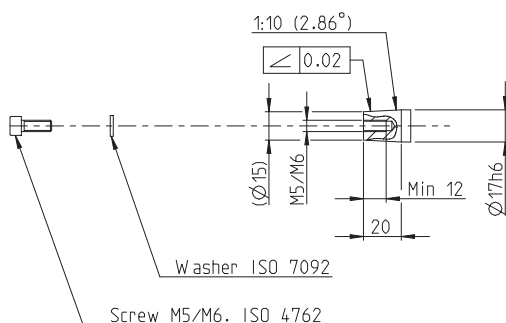

Recommended screw length 25 mm, minimum 8 mm thread in use.

2.5 900 series

2.5.1 Taper hollow shaft with axial fixing screw

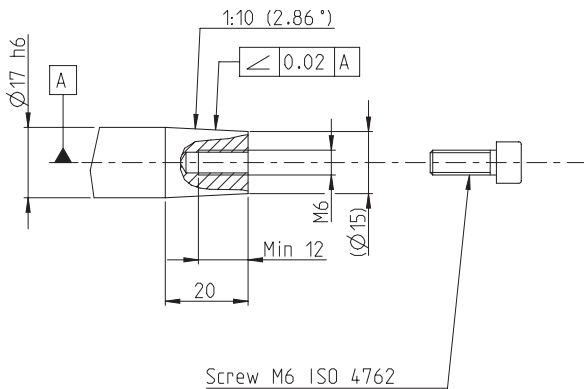

Recommended screw length 25 mm, minimum 8 mm thread in use. Max screw head diameter 10,5 mm.

2.5.2 Blind hollow shaft with axial fixing screw

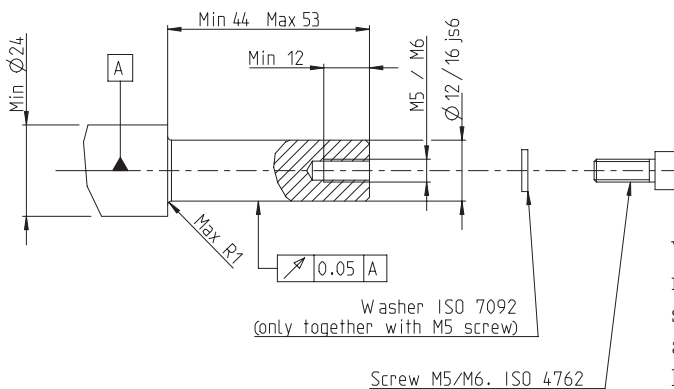

When a 53 mm mating shaft is used the recommended screw length is 16 mm. If the shaft is made shorter the length of the screw must be prolonged accordingly so that minimum 9 mm thread is in use. Max screw head and washer diameter 10,5 mm.

2.5.3 Blind hollow shaft with axial fixing screw and keyway

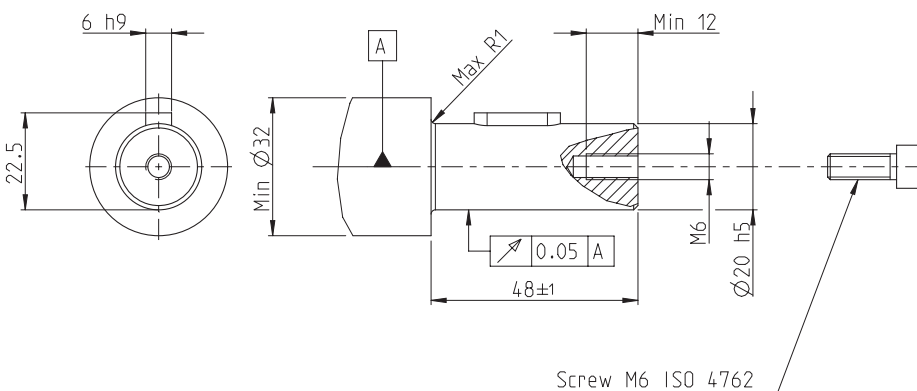

Recommended screw length 16 mm, minimum 9 mm thread in use. Max screw head diameter 10,5 mm.

3 Shaft runout (all series)

Check the encoder's radial runout with slow rotation of complete assembly. The runout should not exceed 0.1 mm, as this may shorten the encoder's service life or influence the system accuracy.

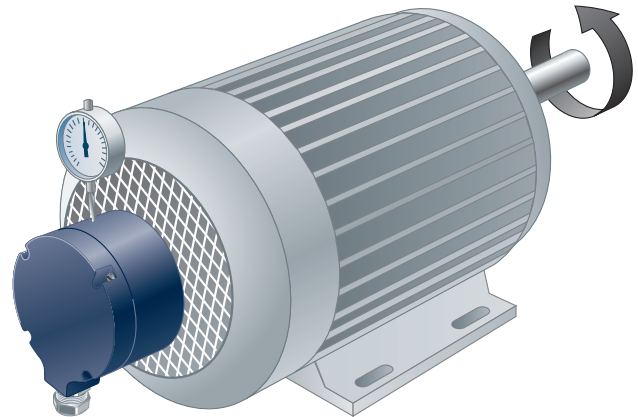

4 Torque arms (800 and 700 series)

Fix the encoder with an insulated torque arm. It must be fitted at 90 degrees angle to the direction of the bracket, for optimum accuracy of measurement.

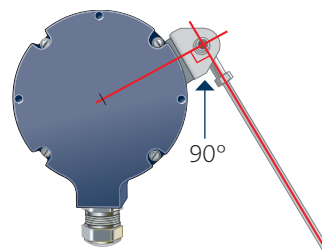

4.1 Accessory torque arms (to be ordered separately)

4.1.2 Mounting with M6 torque arm

Part number 01208014 (800 or 700 series)

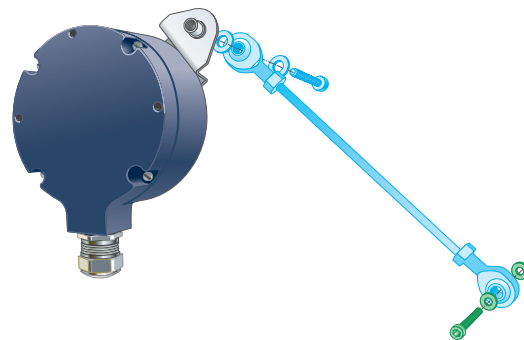

4.1.3 Alt. mounting with M5 torque arm

Part number 01208013 (800 series)

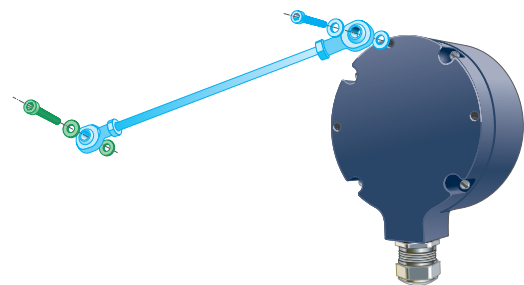

 = Part from customer

 = Accessories from Leine & Linde



The best encoders are those you never have to think about. Those that simply do their job – year after year. Leine & Linde develops and manufactures customised encoder solutions for demanding environments, advanced measuring systems for accurate feedback of speed and position.

LEINE  LINDE

+46-(0)152-26500 www.leinelinde.com