

Tachogeneratoren

Einseitig offene Hohlwelle $\varnothing 16$ mm

Gehäuse $\varnothing 95$ mm, lagerlose Ausführung

GTR 9



GTR 9

Merkmale

- Kurze Reaktionszeit
- Leerlaufspannung 20...60 mV pro U/min
- Einseitig offene Hohlwelle $\varnothing 16$ mm
- Hohe Signalgüte dank patentierter Longlife Technik
- Steckeranschluss
- Keine Hilfsenergie erforderlich

Technische Daten - elektrisch

Reversiertoleranz	$\leq 0,1$ %
Linearitätstoleranz	$\leq 0,15$ %
Temperaturkoeffizient	$\pm 0,05$ %/K (Leerlauf), Option: 0,005 %/K
Isolationsklasse	B
Kalibriertoleranz	± 5 %
Klimatische Prüfung	Feuchte Wärme, konstant (IEC 60068-2-3, Ca)
Leistung	0,9 W (Drehzahl ≥ 5000 U/min)
Ankerkreis-Zeitkonstante	< 5 μ s
Leerlaufspannung	20...60 mV pro U/min
Störfestigkeit	EN 61000-6-2
Störaussendung	EN 61000-6-3
Zulassung	CE

Technische Daten - mechanisch

Baugröße (Flansch)	$\varnothing 95$ mm
Wellenart	$\varnothing 16$ mm (einseitig offene Hohlwelle)
Schutzart DIN EN 60529	IP 56
Drehmoment	0,35 Ncm
Trägheitsmoment Rotor	1,95 kgcm ²
Werkstoffe	Gehäuse: Edelstahl / Kunststoff Welle: Edelstahl
Betriebstemperatur	-30...+130 °C
Widerstandsfähigkeit	IEC 60068-2-6 Vibration 10 g, 10-2000 Hz IEC 60068-2-27 Schock 100 g, 6 ms
Masse ca.	1,1 kg
Anschluss	Stecker

Tachogeneratoren

Einseitig offene Hohlwelle $\varnothing 16$ mm
Gehäuse $\varnothing 95$ mm, lagerlose Ausführung

GTR 9

Bestellbezeichnung

GTR9.16L/4

	Leerlaufspannung
20	20 mV pro U/min
30	30 mV pro U/min
40	40 mV pro U/min
60	60 mV pro U/min

Daten nach Typ

Typ	Leerlaufspannung U_0 [mV/U/min]	Min. erforderlicher Lastwiderstand in Abhängigkeit vom Drehzahlbereich [U/min]			Max. Betriebsdrehzahl n_{max} [U/min]	Anker-Widerstand R_A (20°C) [Ω]	Anker-Induktivität L_A [mH]
		0-3000	0-6000	0- n_{max}			
GTR9.16L/420	20	≥ 7	≥ 16	≥ 36	9000	39	31
GTR9.16L/430	30	≥ 15	≥ 36	≥ 82	9000	84	69
GTR9.16L/440	40	≥ 27	≥ 64	≥ 144	9000	165	122
GTR9.16L/460	60	≥ 60	≥ 144	–	6000	340	275

Überlagerte Welligkeit (für $\tau_{RC} = 0,3$ ms): $\leq 0,4\%$ (Spitze-Spitze) $\leq 0,15\%$ (effektiv)

Ersatzschaltbild

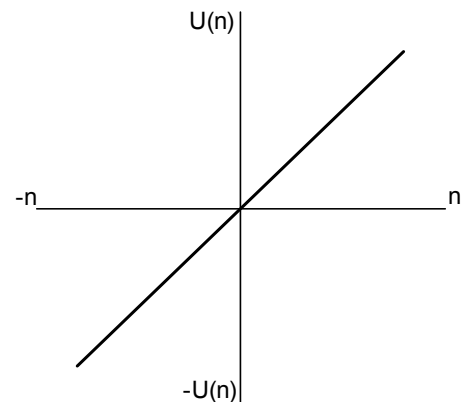
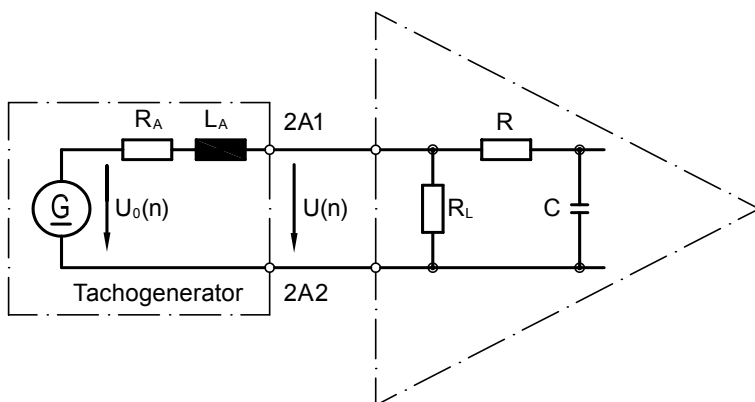

$$\tau_{RC} \approx R \cdot C \quad \tau_A \approx \frac{L_A}{R_L}$$

$$U(n) = U_0(n) \frac{R_L}{R_A + R_L} \approx U_0(n) \text{ für } R > R_L \gg R_A$$

Polarität bei positiver Drehrichtung: 2A1: + 2A2: – (VDE)

Tachogeneratoren

Einseitig offene Hohlwelle $\varnothing 16$ mm

Gehäuse $\varnothing 95$ mm, lagerlose Ausführung

GTR 9

Anschlussbelegung

Ansicht A - Anschlussklemmen

Polarität bei positiver Drehrichtung

Zubehör

Montagekegel

Kohlebürsten

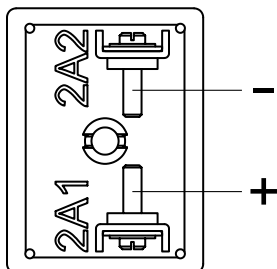

Abmessungen

GTR 9.16

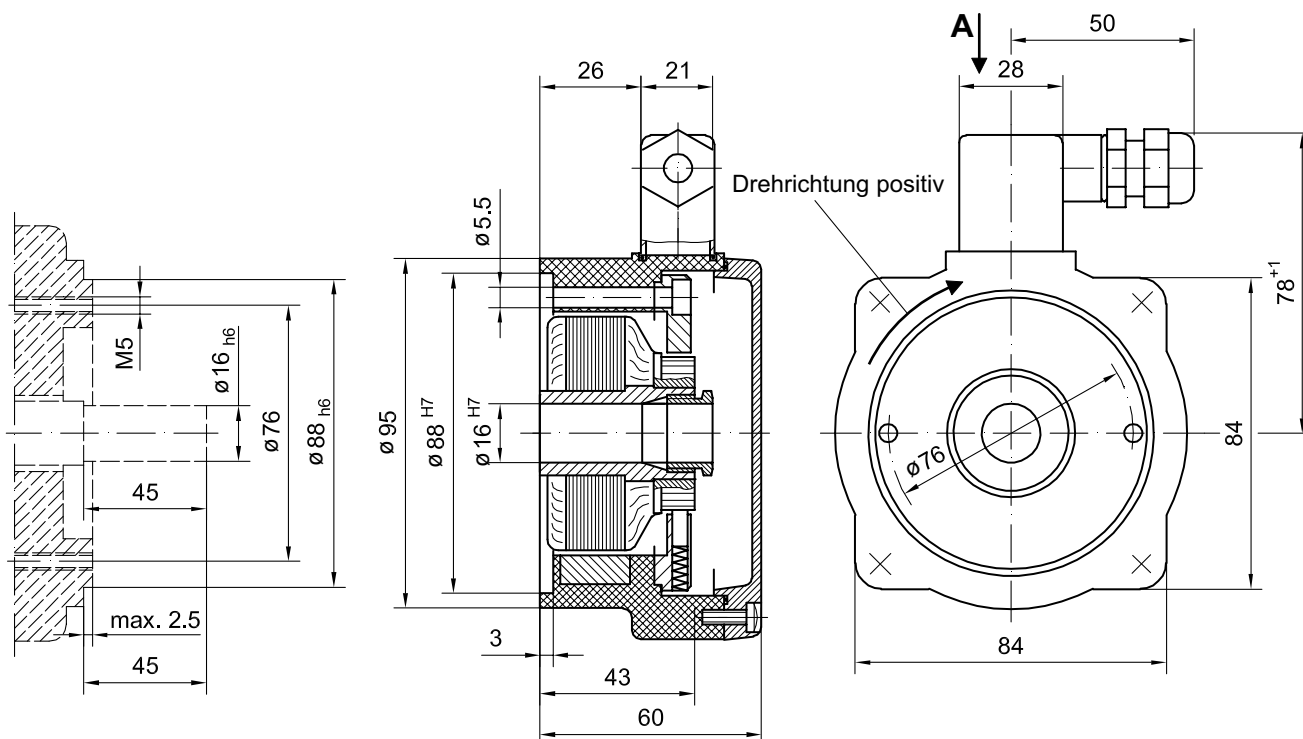

HM87M21438

Tachogenerators

Blind hollow shaft $\varnothing 16$ mm

Housing $\varnothing 95$ mm, bearingless configuration

GTR 9



GTR 9

Features

- Low response time
- Open circuit voltage 20...60 mV per rpm
- Blind hollow shaft $\varnothing 16$ mm
- High signal quality due to patented LongLife technology
- Connector output
- No auxiliary energy source required

Technical data - electrical ratings

Reversal tolerance	≤ 0.1 %
Linearity tolerance	≤ 0.15 %
Temperature coefficient	± 0.05 %/K (open-circuit), optional: 0.005 %/K
Isolation class	B
Calibration tolerance	± 5 %
Climatic test	Humid heat, constant (IEC 60068-2-3, Ca)
Performance	0.9 W (speed ≥ 5000 rpm)
Armature-circuit time-constant	< 5 μ s
Open-circuit voltage	20...60 mV per rpm
Interference immunity	EN 61000-6-2
Emitted interference	EN 61000-6-3
Approval	CE

Technical data - mechanical design

Size (flange)	$\varnothing 95$ mm
Shaft type	$\varnothing 16$ mm (blind hollow shaft)
Protection DIN EN 60529	IP 56
Torque	0.35 Ncm
Rotor moment of inertia	1.95 kgcm ²
Materials	Housing: stainless steel / plastic Shaft: stainless steel
Operating temperature	-30...+130 °C
Resistance	IEC 60068-2-6 Vibration 10 g, 10-2000 Hz IEC 60068-2-27 Shock 100 g, 6 ms
Weight approx.	1.1 kg
Connection	Connector

Tachogenerators

Blind hollow shaft $\varnothing 16$ mm
Housing $\varnothing 95$ mm, bearingless configuration

GTR 9

Part number

GTR9.16L/4

	Open-circuit voltage
20	20 mV per rpm
30	30 mV per rpm
40	40 mV per rpm
60	60 mV per rpm

Data according to type

Type	Off-load voltage U_0 [mV/rpm]	Minimum load required depending on speed range [rpm]			Maximum operating speed n_{max} [rpm]	Armature resistance R_A (20°C) [Ω]	Armature inductance L_A [mH]
		0-3000	0-6000	0- n_{max}			
		R_L [k Ω]	R_L [k Ω]	R_L [k Ω]			
GTR9.16L/420	20	≥ 7	≥ 16	≥ 36	9000	39	31
GTR9.16L/430	30	≥ 15	≥ 36	≥ 82	9000	84	69
GTR9.16L/440	40	≥ 27	≥ 64	≥ 144	9000	165	122
GTR9.16L/460	60	≥ 60	≥ 144	–	6000	340	275

Superimposed ripple (for $\tau_{RC} = 0.3$ ms): $\leq 0.4\%$ (peak-peak) $\leq 0.15\%$ (rms)

Replacement switching diagram

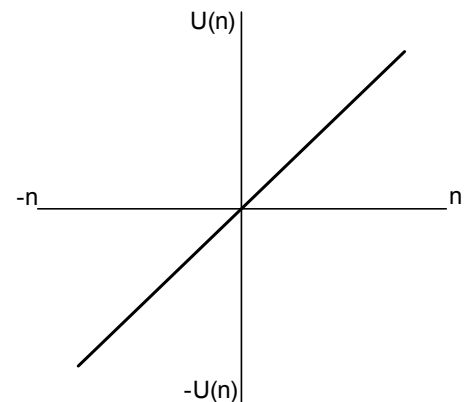
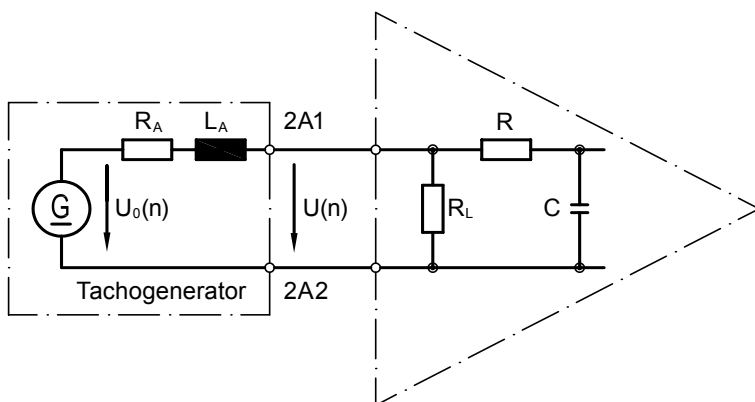

$$\tau_{RC} \approx R \cdot C \quad \tau_A \approx \frac{L_A}{R_L}$$

$$U(n) = U_0(n) \frac{R_L}{R_A + R_L} \approx U_0(n) \text{ for } R > R_L \gg R_A$$

Polarity for positive rotating direction: 2A1: + 2A2: - (VDE)

Tachogenerators

Blind hollow shaft $\varnothing 16$ mm

Housing $\varnothing 95$ mm, bearingless configuration

GTR 9

Terminal assignment

View A - Connecting terminal

Polarity for positive direction of rotation

Accessories

Mounting cone

Carbon brushes

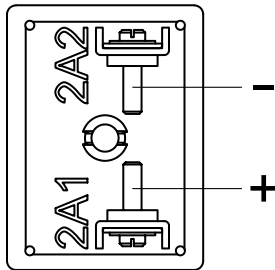

Dimensions

GTR 9.16

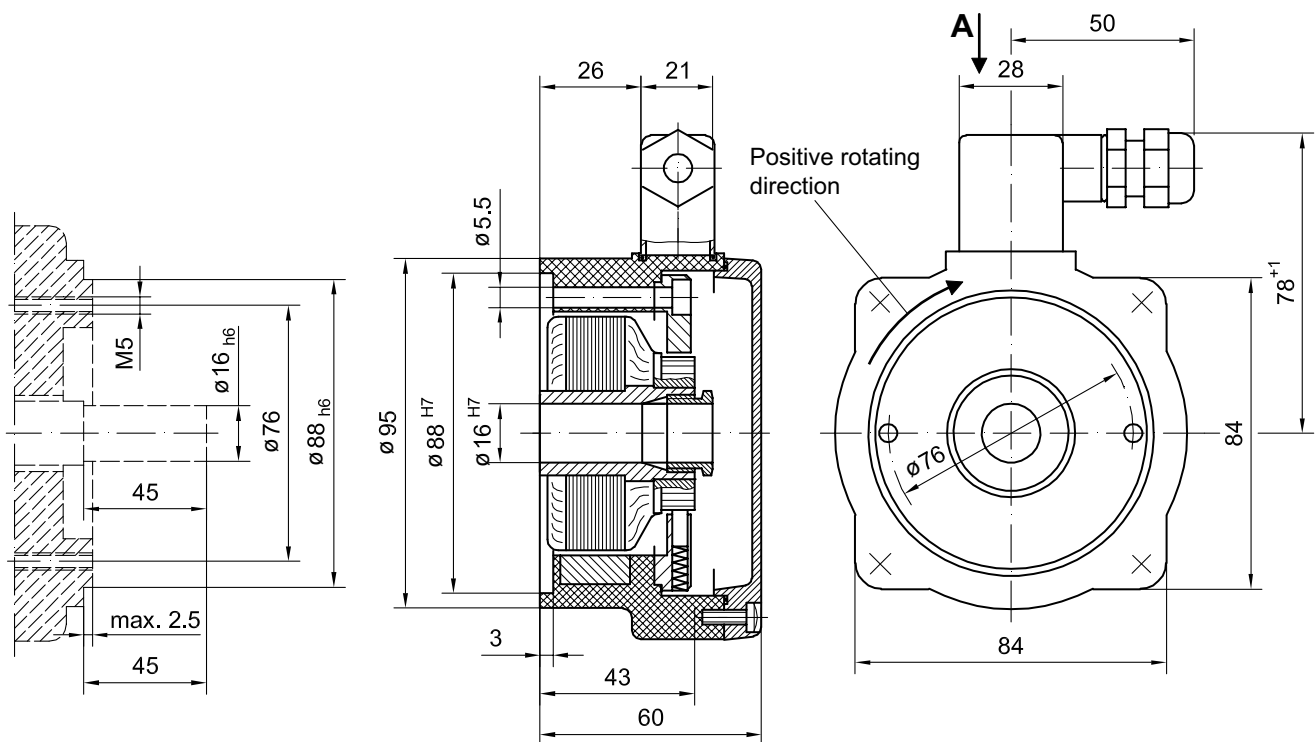

HM87M21438